

10/100 BASE-TX Filtered SMD Connector Module MODEL NO : RJSL-003TC1

Features:

- ⊙ RoHS Compliant
- ⊙ Not use the controlled substances defined in SS-00259
- ⊙ Fully shielded magnetics protect data from internally generated digital noise
- ⊙ Reduces the overall length of the signal path for improved common mode performance
- ⊙ Implements full common mode termination scheme with used and unused twisted pairs
- ⊙ Meets IEEE802.3 Baseline Wander Compensation specification
- ⊙ Integrates high voltage capacitor to chassis ground
- ⊙ Supports all major transceivers with matched turns ration and complete integration of specified termination
- ⊙ Design for 100base-tx transmission over UTP-5 cable
- ⊙ Operating TEMP. range: -40°C to +85°C
- ⊙ Storage TEMP. range: -55°C to + 125°C
- ⊙ Primary OCL inductance: 350μH MIN. at 100KHz/0.1Vrms with 8mA DC bias

Typical Performance Characteristics@ 25°C

Insertion Loss (dB MAX)	Return Loss (dB Min @100±15Ω)				Differential to Common Mode Rejection (dB MIN)	Cross talk (dB MIN)					CMRR (dB MIN)	Isolation Voltage (Vrms min)
	MHz	MHz				MHz	MHz					
1~100	1~30	40	50	60~80	1~100	20	40	60	80	100	1~100	1500
-1.0	-16	-14	-12	-10	-33	-47	-40	-37	-35	-33	-30	

Schematic:

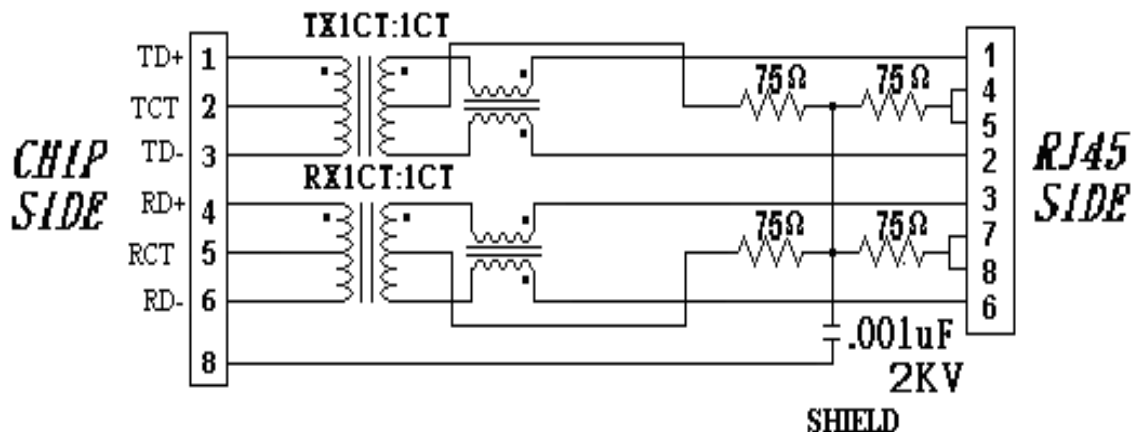

MODEL NO : RJSL-003TC1

Dimension: mm

TOLERANCE: ± 0.15 (unless otherwise specified)

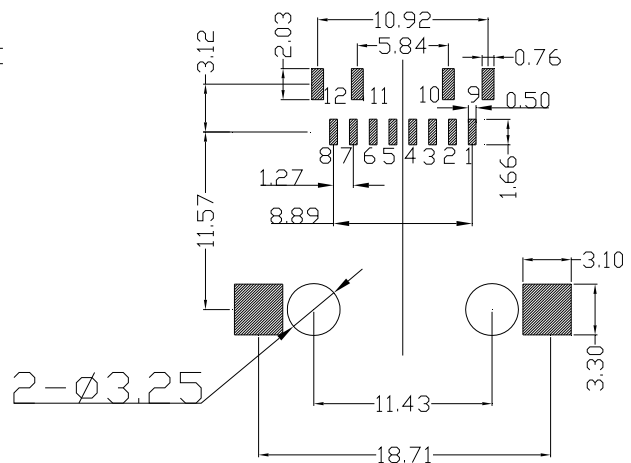
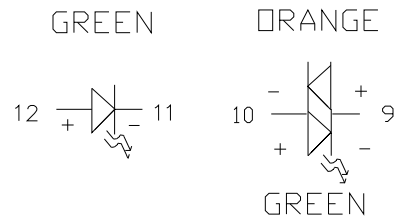
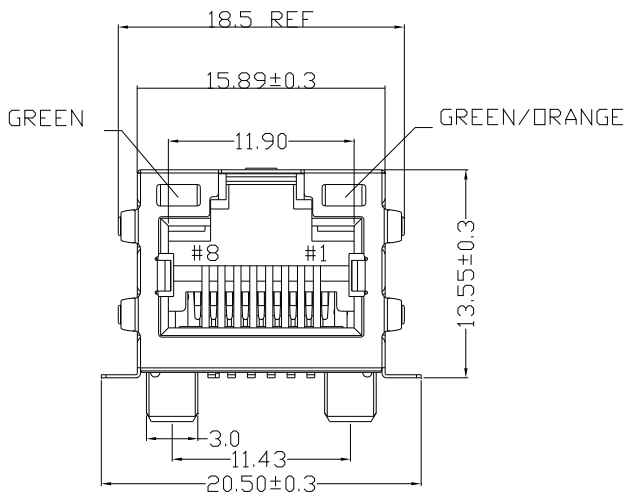
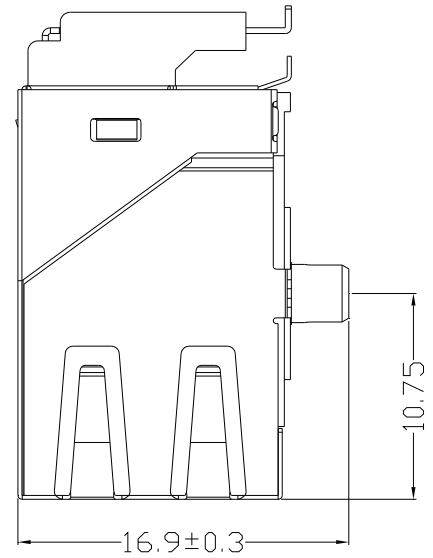
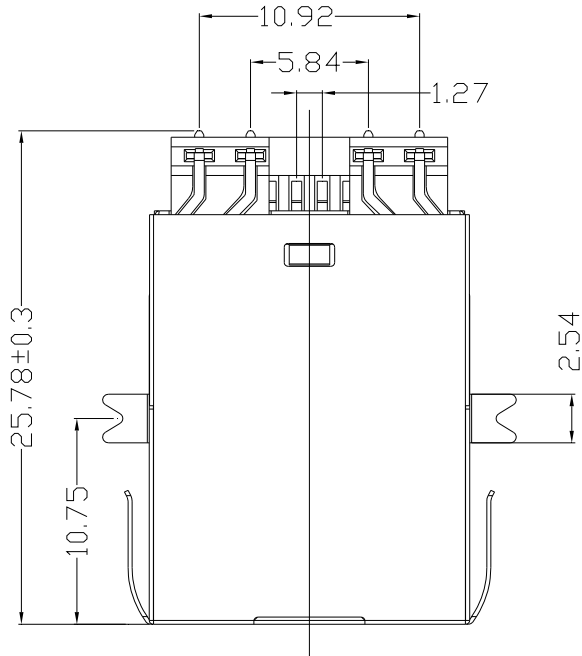

RECOMMENDED P.C.B LAYOUT
COMPONENT SIDE OF BOARD

MODEL NO : RJSL-003TC1

Ordering Information

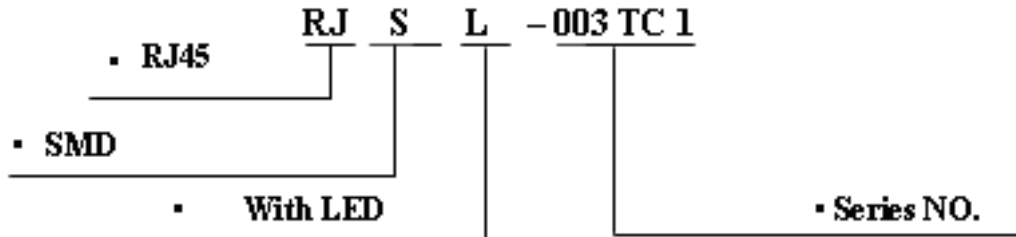

Requirements :

1. Design and Construction

Product shall be of design, construction and physical dimensions specified on applicable product drawing.

2. Materials and Finish

A. Contact:

RJ Contact : Phosphor Bronze, Thickness=0.30mm

Finish : Contact Area :6 μ "min. Gold over 50 μ "min. Nickel

RJ Joint Contact : SPCC, Thickness=0.20mm

Finish : 80 μ "min. Sn over 50 μ "min. Nickel

LED Joint Contact : SPCC, Thickness=0.20mm

Finish : 80 μ "min. Sn over 50 μ "min. Nickel

B. Plastic Part :

(1) Set Housing : Thermoplastic, LCP, Black

UL FILE NO. : E106764

Manufacturer : POLYPLASTICS CO LTD.

Grade : E130i(d)(e)

Flame Class : UL 94V-0

(2) Insert : Thermoplastic, LCP, Black

UL FILE NO. : E106764

Manufacturer : POLYPLASTICS CO LTD.

Grade : E130i(d)(e)

Flame Class : UL 94V-0

(3) Thermoplastic, LCP, Black

UL FILE NO. : E106764

Manufacturer : POLYPLASTICS CO LTD.

Grade : E130i(d)(e)

Flame Class : UL 94V-0

MODEL NO : RJSL-003TC1

C. Shield Material :

Cartridge $t=0.25\pm 0.05\text{mm}$

10 μ "-20 μ " Thick Nickel over Brass

D. LED Lamp

(a) Lens Color : Transparent with color

(b) Emitted Color : Green & Yellow

(c) View Angle : 60°

(d) Wave Length : Green 570nm ; Orange 610nm

(e) Recommended operation current (IF) : 20 mA

Durability :

- (1) 1000 cycles with no function damage for RJ-45 . Abnormalities shall be present after the test.
- (2) Low Level Contact Resistance : $\Delta R=30\text{m}\Omega$ maximum (final)
- (3) The sample should be mounted in the tester and fully mated and unmated 500 times per hour at the rate of 25mm/min. EIA-364-09C.

RJ PLUG SPECIFICATION :

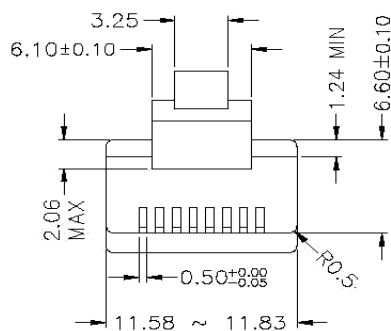

- * There must be no damage to housing or locking latch. There must be no nicks or cuts in cable.
- * Durability : 750 cycles generally

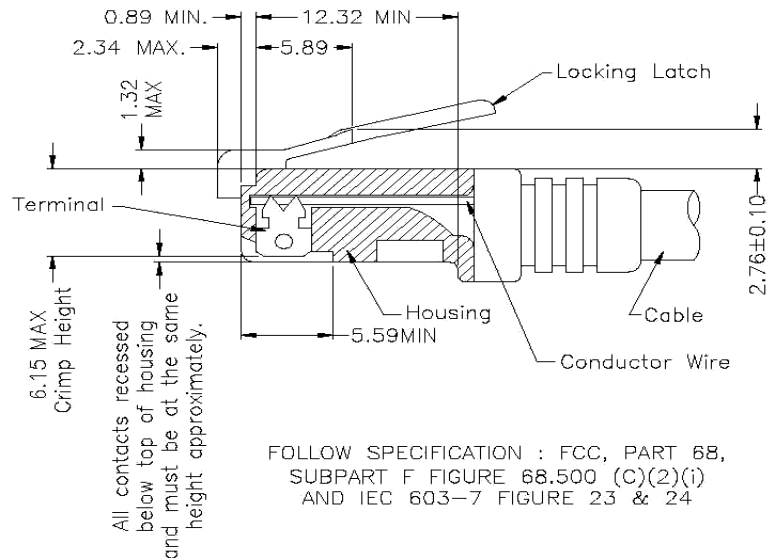

FOLLOW SPECIFICATION : FCC, PART 68,
SUBPART F FIGURE 68.500 (C)(2)(i)
AND IEC 603-7 FIGURE 23 & 24

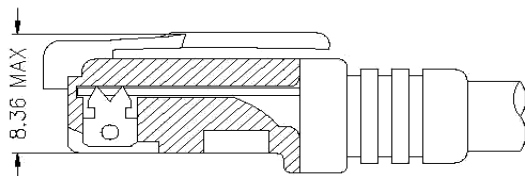

STANDARD MODULAR PLUG ASSEMBLY

FOLLOW SPECIFICATION : FCC, PART 68, SUBPART F
FIGURE 68.500 (C)(2)(ii)

MODEL NO : RJSL-003TC1

Solder Reflow profile for Lead-Free packages.

Package Peak Reflow Temperatures

Classification Reflow Profiles

Profile Feature	Lead-Free Assembly	
Average ramp-up rate(T_L to T_P)	3°C / Second Max.	
Preheat Temperature Min.(T_s min.) Temperature Max.(T_s max.) Time (min to max) (t_s)	150 °C 200 °C 60-180 sec	
T_s max. to T_L Ramp-up Rate	3°C / Second Max.	
Time maintained above Temperature (T_L) Time (t_L)	217 °C 60-150 sec	
Peak Tempure (T_p) Time within 5 °C of actual peak Temp.	260 +0 / -5 °C 3 to 5 Sec	250 +0 / -5 °C 20 to 40 Sec
Ramp-down	6°C / Second Max.	
Time 25 °C to Peak Temperature	8 minutees Max.	

Profile

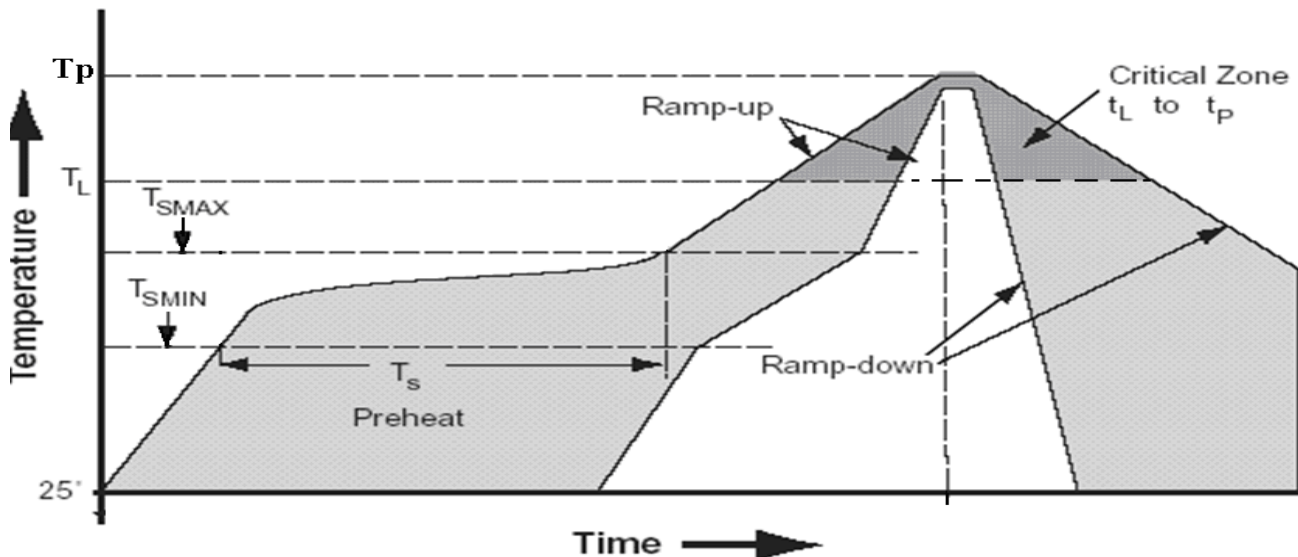

MODEL NO : RJSL-003TC1

PACKING :

1. Unit weight : 4.5 grams
2. Tape & Reel : 100pcs / Reel , 500pcs / Carton
3. Dry Pack : 1pcs
 - Product Description:(5g Silica Gel Desiccant)
 - PH: 4-8
 - Package Materials: Paper(Length 6.5±1cm , Width 5±1cm)
4. Reel Packed By Vacuum
5. Seal Per Jedec

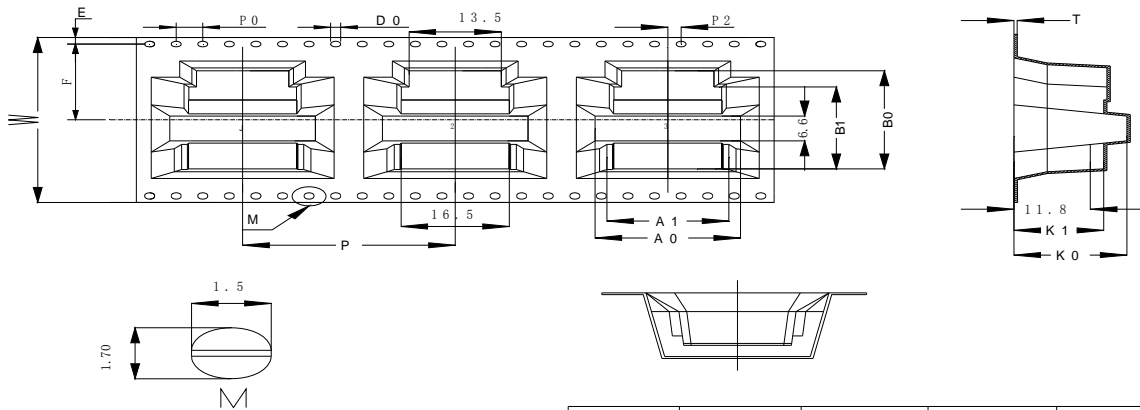

ITEM	W	A ₀	A ₁	B ₀	B ₁	K ₀	K ₁	P	F	T
DIM	44.0 ^{+0.30} _{-0.00}	21.9 ^{+0.10} _{-0.10}	19.5 ^{+0.10} _{-0.10}	27.0 ^{+0.10} _{-0.10}	21.9 ^{+0.10} _{-0.10}	17.3 ^{+0.10} _{-0.10}	13.8 ^{+0.10} _{-0.10}	32.0 ^{+0.10} _{-0.10}	20.2 ^{+0.10} _{-0.10}	0.50 ^{+0.10} _{-0.10}

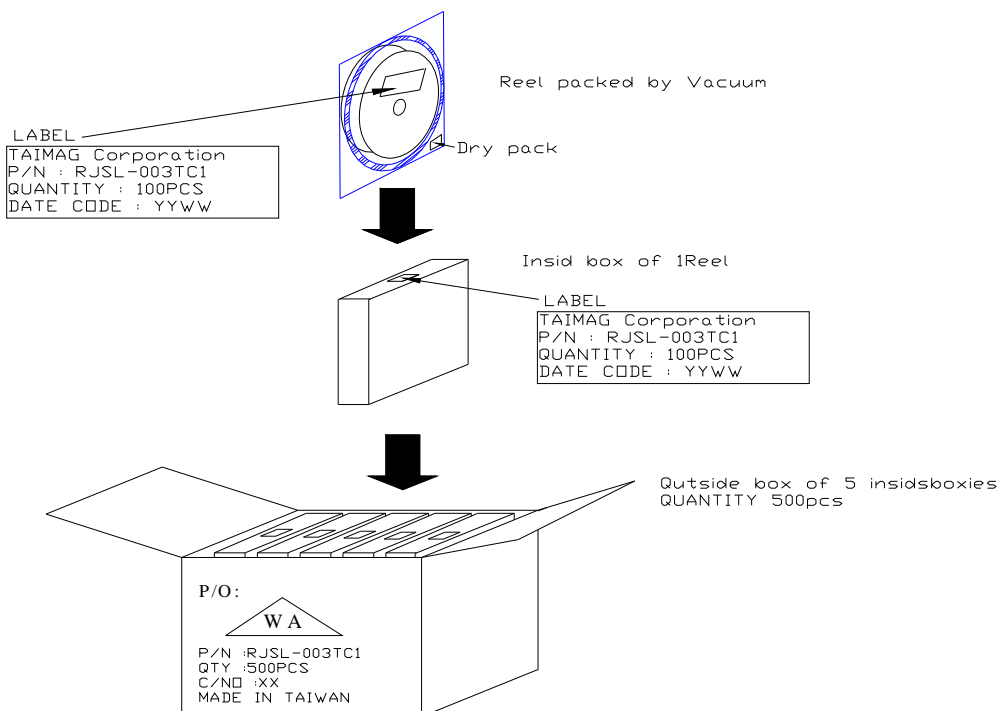



MBER:RD-SDMIC2412A-5101W-LF1(Mi)
DATE :2015/10/02 H (REV:A9)

MODEL NO : RJSL-003TC1

REV.	Revision Description	DATE	APPROVED
A1	First Release	2006/04/07	
A2	Update data	2007/07/30	
A3	Update Packing	2008/09/10	
A4	Update Dimension	2009/09/21	
A5	Update Packing & LCP	2009/09/23	
A6	ADD IR Reflow profile	2010/05/08	
A7	Add Dimension	2011/07/07	
A8	Update Dimension	2013/05/14	
A9	Update Not use the controlled substances defined in SS-00259	2015/10/02	